

Epec Power Distribution Unit (PDU)

ONE PAGER PDU

Product one pager for active PDU EN1P

TRACTION VOLTAGE POWER DISTRIBUTION UNIT FOR ELECTRIC VEHICLES/ MACHINES TRACTION AND AUXILIARY HIGH VOLTAGE:

- Active unit include traction voltage contactors and contactor controls with Voltage and current measurement units.
- Pre-charging circuit to balance voltage levels before and after contactors
- charging connection with contactor switching
- High voltage circuit insulation resistance measurement & monitoring
- Fuse protection for high and low current component output
- Hazardous voltage interlock loop (HVIL)
- Robust unit which is configurable for different high voltage distribution demands

MAIN DIMENSIONS:

- Overall dimensions: 503 x 372 x 172 mm
- Weight: 21 kg
- Mounting to vehicle: all other orientation allowed than Cables upside
- Mounting by customer designed brackets by M8 screw from each side

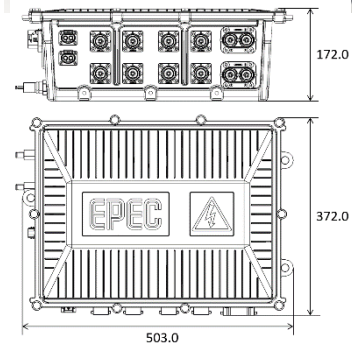

SCHEMATIC DIAGRAM

Example of High voltage circuit control block diagram for active PDU

1. Control unit: Epec controller
2. Insulation monitoring unit
3. Voltage measurement
4. Current measurement
5. Main contactors with pre-charge contactors
6. DC-charging contactors
7. Temperature measurement inside PDU
8. HVIL loop for all connectors and covers

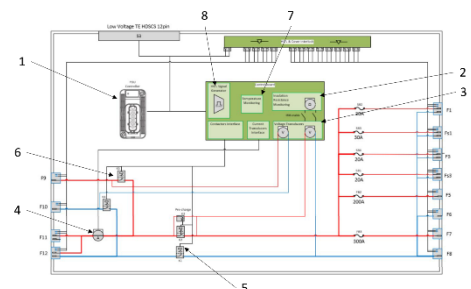

TECHNICAL DATA

FEATURE	VALUE	NOTE
Thermal management	Water cooling option	16 mm Hose barb or VDA NW12 standard quick connection
Communication	CANopen interface (SAEJ1939 support also)	12 or 24 V LV operating voltage for PDU controller
Operating Voltage	500-800 V	1000 V optional
Operating current	400 A (RMS)	Continuous current
Current peak	600 A	Peak 60 s
Connections	2x battery connections 4x High current connections 3x Low current connections 1x DC charging	Connections can be varied based on customer need
Safety	All connections IPXXB and HVIL	Electric safety according to IEC61800-5
Battery connection	Main contactors for battery connection with Pre-charging circuit	500 A max switching current
Insulation monitoring	Full HV-system monitoring,	Alarming limit: min 500 kΩ, possible to isolate from DC-link
Sensors	Voltage (Battery and HV grid) Current (Battery and HV grid) Temperature	
HVIL circuit	Covers and connectors included	Safety lid included (min 10 s safety time from cover opening) redundant cover opening circuit.
Fuses	High current connections up to 600 A/800 Vdc Low current connections up to 50 A/800 Vdc	Fuse sizing shall be done at integration project with customer
Control system	Epec controller	
Operating condition	In operation -40 °C to +60 °C IP67 and IP69K Max 2000 m	
Size	503 x 370 x 172 mm	Aluminum enclosure
Output power	100- 400 kW	

ONE PAGER PDU



[PDU Product Page](#)

YOUR CHALLENGE, OUR INSPIRATION.



OUTSIDE INTERFACES:

1. Signal connector
2. Low current connector
3. DC charging
4. High current component
5. Battery connection
6. Grounding point, M8 thread
7. Mounting screw hole, 8x M8
8. Cooling inlet, VDA NW12
9. Cooling outlet, VDA NW12
10. Gore Vent
11. Coolant bleeding plug

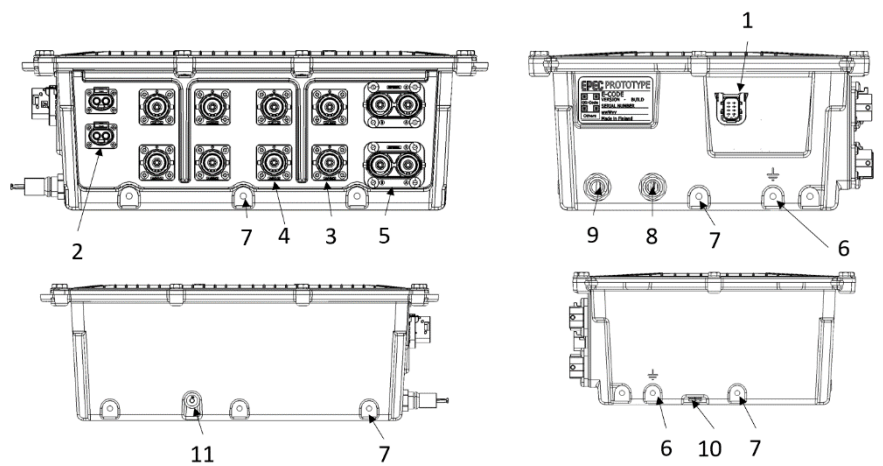
**CONFIGURABLE OPTIONS****Connections**

- On board service charger (max 50A)
- DC charging (max 500A)
- High voltage connections; amount, location and connector type
- Fuse sizes

Preferred connectors

- Amphenol Powerlok 300 gen II
- Amphenol ePower Lite (up to 100A)
- Amphenol HSVLS 600
- Amphenol Powerlok 60
- Hirshmann HPS40-2
- TE HVA 280
- Cable glands as customized version

